

J0181

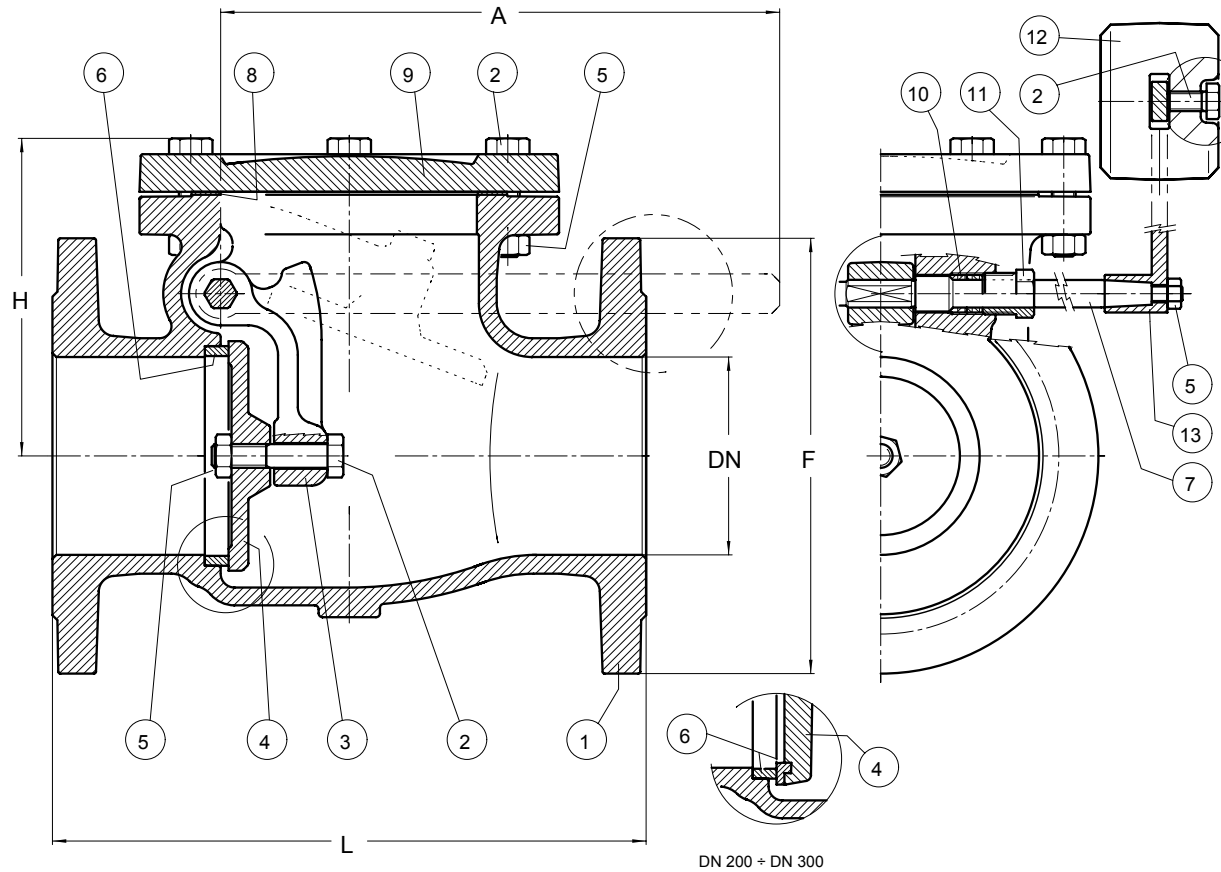

POS.	PARTS	MATERIALS
1	BODY	GG25 CAST IRON
2	SCREW	8.8 CARBON STEEL
3	HINGE	GG25 CAST IRON
4	SWING	CAST BRASS DN40-DN150
4	SWING	GG25 CAST IRON+CAST BRASS RING DN200-DN300
5	NUT	CARBON STEEL
6	SEAT	CAST BRASS
7	PIN	X12Cr13
8	GASKET	FASIT 205
9	BONNET	GG25 CAST IRON
10	PACKING	PTFE
11	PACKING GLAND	DRAWN BRASS
12	WEIGHT	GG25 CAST IRON
13	LEVER	CARBON STEEL

Max temperature with standard gaskets +80°C

On request gaskets suitable for temperature >80°C

DN	40	50	65	80	100	125	150	200	250	300
F	150	165	185	200	220	250	285	340	405	460
L	180	200	240	260	300	350	400	500	600	700
H	115	125	130	140	160	180	200	220	290	330
A	193	193	218	243	278	306	356	406	575	575
Kg	11	12	17	22	29	39	53	77	138	203

F = ISO 7005-2 PN16

L = EN 558-1 BASIC SERIES 48

Hydraulic test ISO 5208 RATE A	
Maximum rated pressure in relation to temperature and material	
Pressure	Temperature
16 bar	-10°C/+80°C
16 bar	+80°C/+120°C
13 bar	+120°C/+150°C