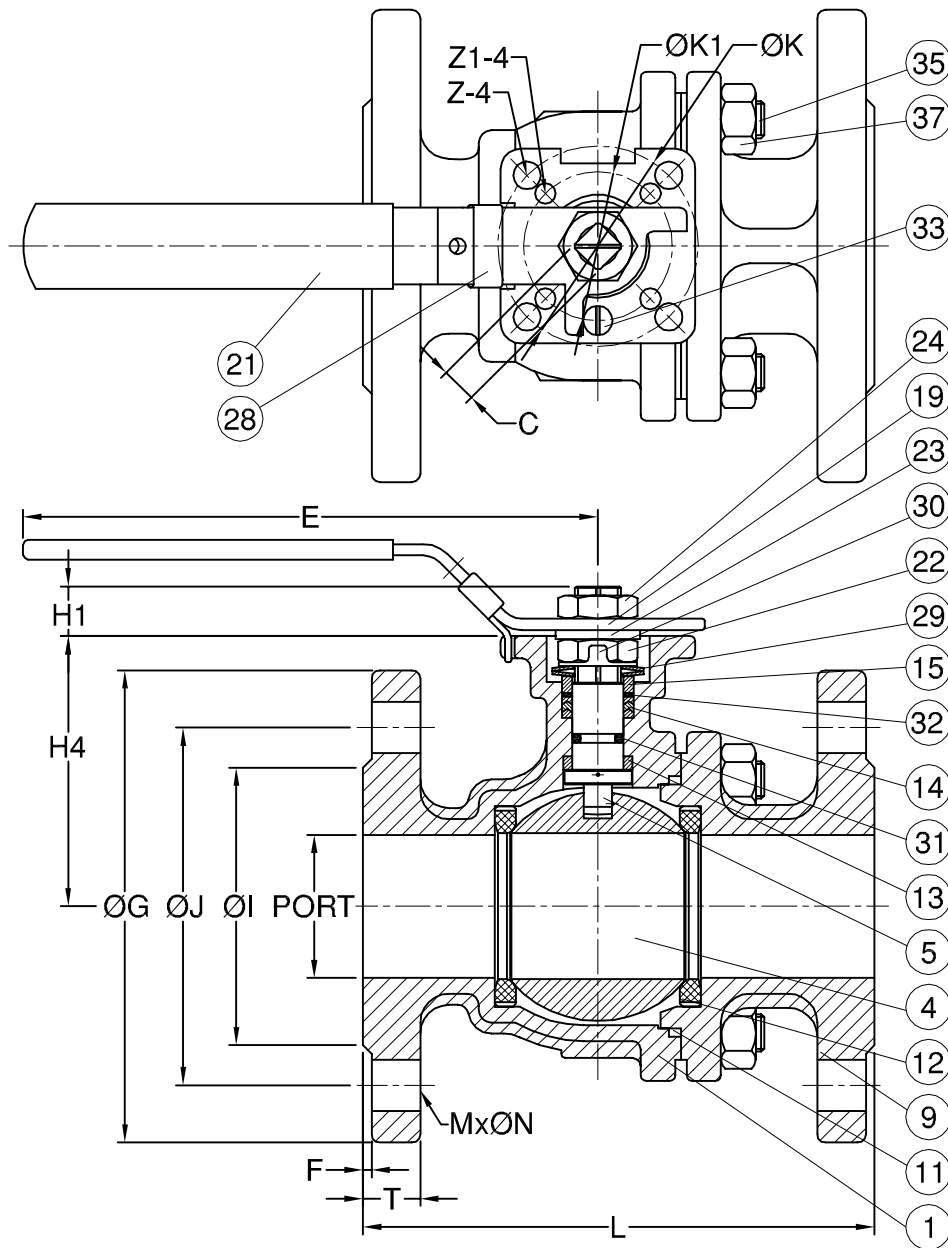

Fig No: D028



MATERIALS LIST

NO.	PART NAME	MATERIAL
1	BODY	1.4408 / EN1503-1
4	BALL	CF8M / EN1503-2
5	STEM	SS316
9	END CAP	1.4408 / EN1503-1
11	BODY SEAL	PTFE.
12	SEAT	RTFE.
13	THRUST WASHER	PTFE.
14	STEM PACKING	PTFE.
15	GLAND	SS304
19	HANDLE	SS304
21	HANDLE COVER	PLASTIC
22	STEM NUT	SS304
23	HANDLE WASHER	SS304
24	HANDLE NUT	SS304
28	LOCKING PAD	SS304
29	BELLEVILLE WASHER	SS304
30	TAB WASHER	SS304
31	O-RING	VITON
32	PACKING FOLLOWER	RTFE.
33	STOP PIN	SS304
35	BODY STUD	ASTM A193 Gr.B8
37	BOLT NUT	ASTM A194 Gr.8

DIMENSIONS

unit:mm

SIZE	PORT	L	E	H1	H4	C	ØG	ØJ	ØI	T	F	M	ØN	ØK	ØK1	Z	Z1	
DN15	1/2"	15.0	115.0	112.0	8.5	48.0	9.0	95.0	65.0	45.0	16.0	2.0	4	14.0	50.0	36.0	7.0	6.0
DN20	3/4"	20.0	120.0	112.0	8.5	62.0	9.0	105.0	75.0	58.0	18.0	2.0	4	14.0	50.0	36.0	7.0	6.0
DN25	1"	25.0	125.0	136.0	11.4	64.0	9.0	115.0	85.0	68.0	18.0	2.0	4	14.0	50.0	36.0	7.0	6.0
DN32	1-1/4"	32.0	130.0	185.0	11.4	71.0	9.0	140.0	100.0	78.0	18.0	2.0	4	18.0	50.0	36.0	7.0	6.0
DN40	1-1/2"	38.0	140.0	198.0	14.0	76.0	14.0	150.0	110.0	88.0	18.0	2.0	4	18.0	70.0	50.0	9.0	7.0
DN50	2"	50.0	150.0	198.0	13.7	84.5	14.0	165.0	125.0	102.0	20.0	2.0	4	18.0	70.0	50.0	9.0	7.0
DN65	2-1/2"	63.0	170.0	265.0	18.0	106.8	17.0	185.0	145.0	122.0	18.0	2.0	4	18.0	102.0	70.0	11.0	9.0
DN80	3"	80.0	180.0	265.0	18.0	116.0	17.0	200.0	160.0	138.0	20.0	2.0	8	18.0	102.0	70.0	11.0	9.0
DN100	4"	98.0	190.0	325.0	18.0	154.5	17.0	220.0	180.0	158.0	20.0	2.0	8	18.0	102.0	70.0	11.0	9.0

FLANGE DIMENSION: EN 1092-1 TYPE 21 RF SF
FACE TO FACE: EN558-1 F4 (DIN3202 F4)

Fig No: D028

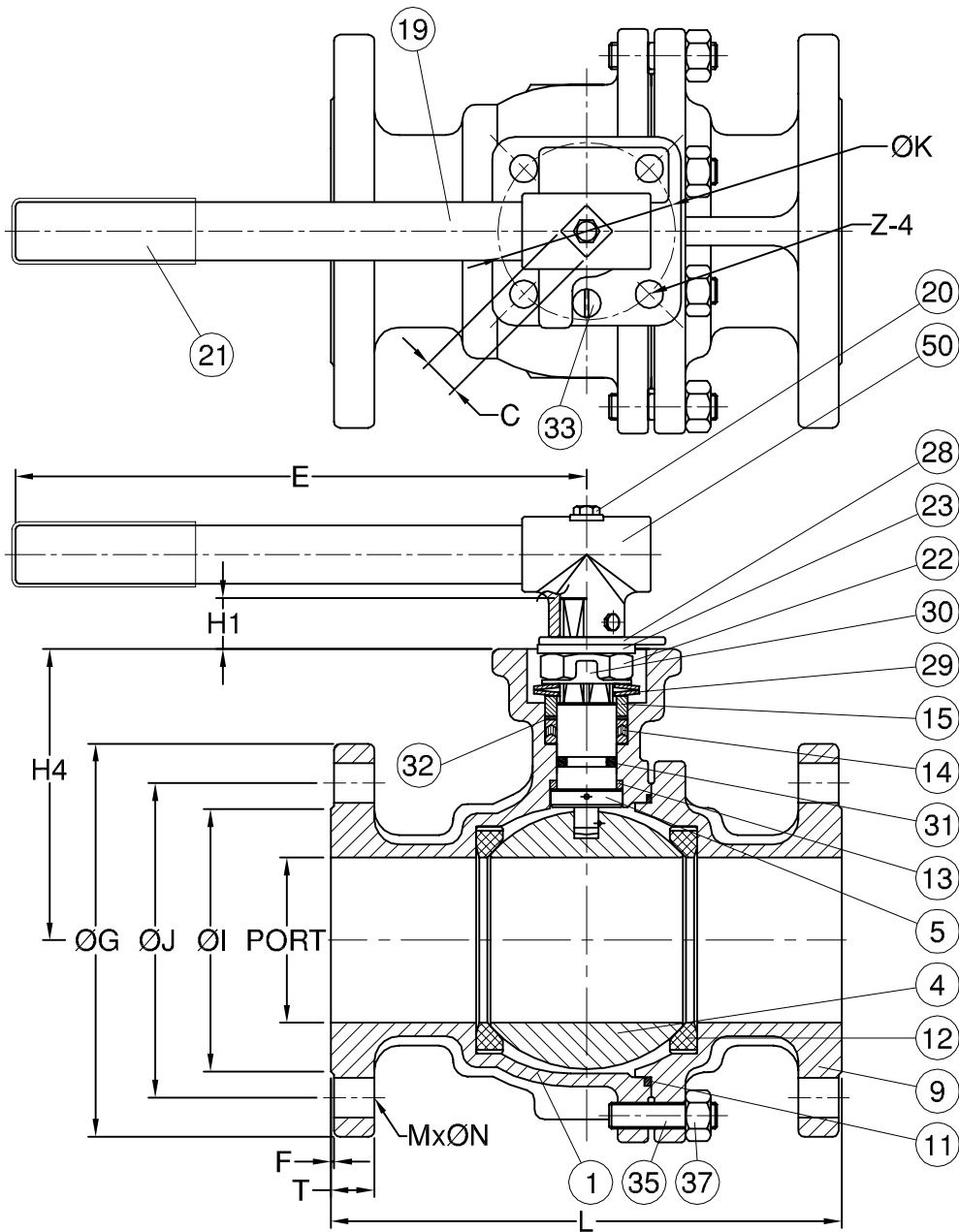

MATERIALS LIST

NO.	PART NAME	MATERIAL
1	BODY	1.4408 / EN1503-1
4	BALL	CF8M / EN1503-2
5	STEM	SS316
9	END CAP	1.4408 / EN1503-1
11	BODY SEAL	PTFE.
12	SEAT	RTFE.
13	THRUST WASHER	PTFE.
14	STEM PACKING	PTFE.
15	GLAND	SS304
19	HANDLE	SS304
20	SET SCREW	SS304
21	HANDLE COVER	PLASTIC
22	STEM NUT	SS304
23	HANDLE WASHER	SS304
28	STOP PLATE	SS304
29	BELLEVILLE WASHER	SS304
30	TAB WASHER	SS304
31	O-RING	VITON
32	PACKING FOLLOWER	RTFE.
33	STOP PIN	SS304
35	BODY STUD	ASTM A193 Gr.B8
37	BOLT NUT	ASTM A194 Gr.8
50	ADAPTER	SS304

DIMENSIONS

unit:mm

SIZE	PORT	L	E	H1	H4	C	ØG	ØJ	ØI	T	F	M	ØN	ØK	Z	
DN125	5"	125.0	325.0	600.0	30.0	194.0	27.0	250.0	210.0	188.0	22.0	2.0	8	22.3	125.0	14.0
DN150	6"	150.0	350.0	800.0	30.0	213.0	27.0	285.0	240.0	212.0	22.0	2.0	8	22.3	125.0	14.0

FLANGE DIMENSION: EN 1092-1 TYPE 21 RF SF

FACE TO FACE: EN558-1 F5 (DIN3202 F5)