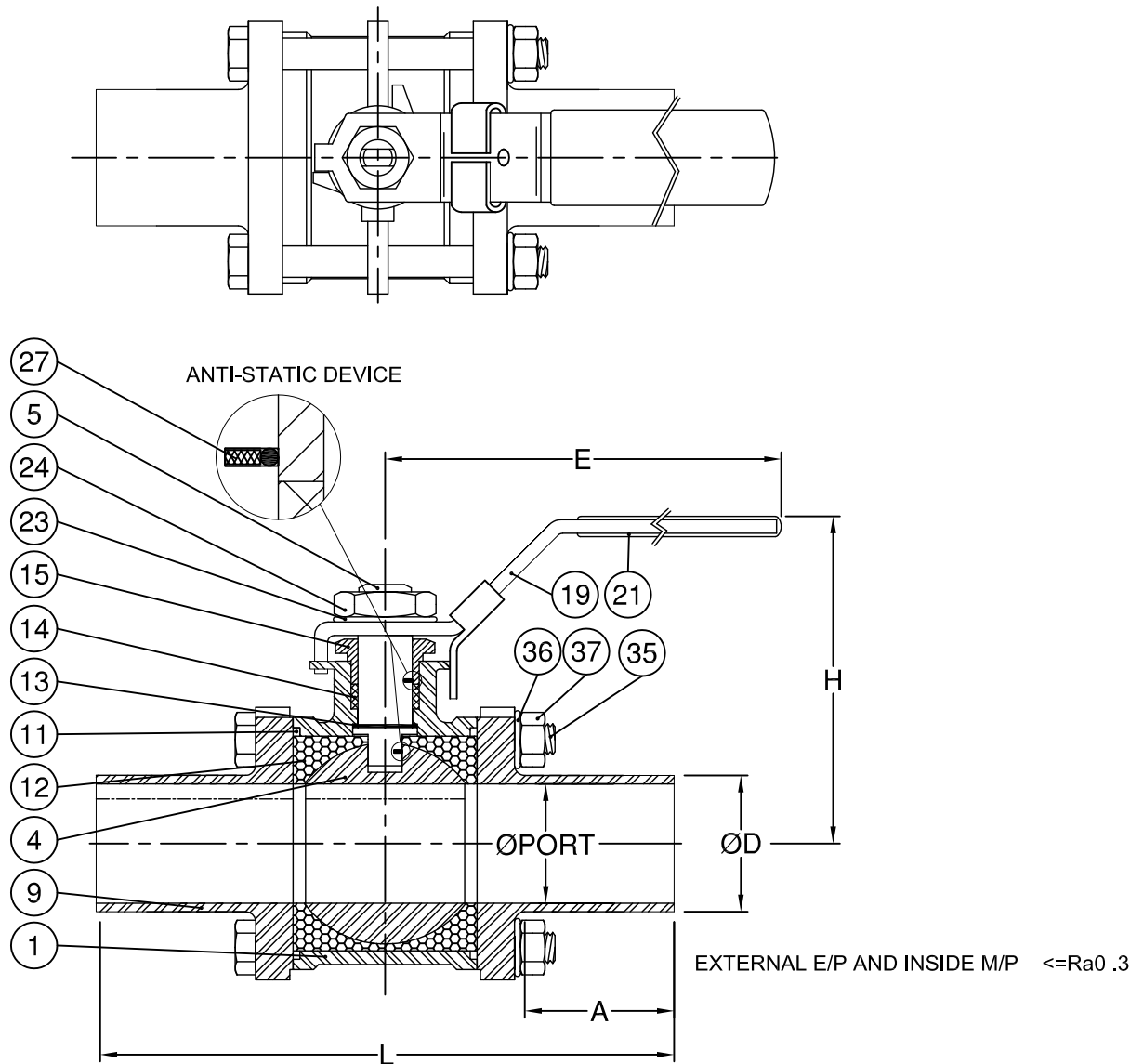

Fig No: **DZ15A04**

MATERIAL LIST

NO.	PART NAME	MATERIAL
1	BODY	ASTM A351 Gr.CF8M
4	BALL	ASTM A351 Gr.CF8M
5	STEM	SS316
9	END CAP	ASTM A351 Gr.CF3M
11	BODY SEAL	PTFE
12	SEAT	PTFE
13	THRUST WASHER	PTFE
14	STEM PACKING	PTFE
15	GLAND BUSH	SS304
19	HANDLE	SS304
21	HANDLE COVER	PLASTIC
23	HANDLE WASHER	SS304
24	HANDLE NUT	SS304
27	ANTI-STATIC DEVICE	ASSEMBLY
35	BODY BOLT	SS304
36	BOLT WASHER	SS304
37	BOLT NUT	SS304



DIMENSION

unit:mm

SIZE	PORT	L	A	ØD	E	H	TORQUE
DN10	3/8"	10	121.0	41.0	13	106.0	60.0
DN15	1/2"	16	123.7	41.0	19	106.0	70.0
DN20	3/4"	20	130.0	41.0	23	106.0	85.0
DN25	1"	26	138.1	41.0	29	135.0	160.0
DN32	1-1/4"	32	147.0	41.0	35	135.0	180.0
DN40	1-1/2"	38	163.4	41.0	41	182.0	230.0
DN50	2"	50	172.6	41.0	53	182.0	350.0