

J0170

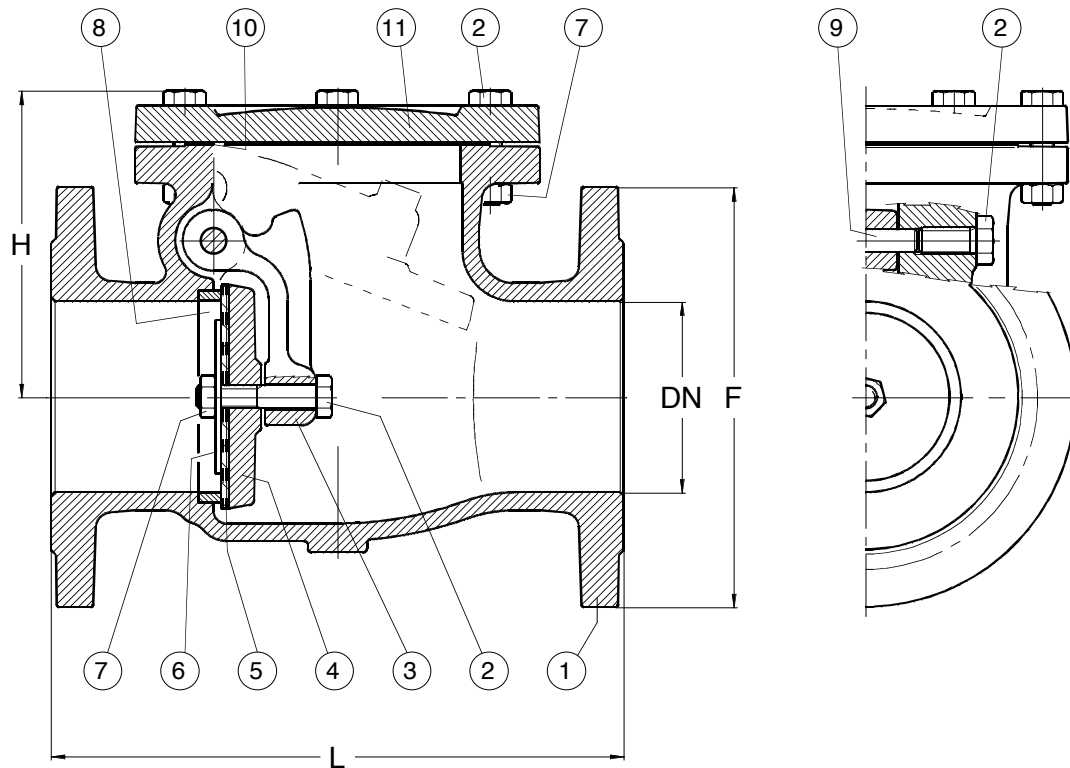

POS.	PARTS	MATERIALS
1	BODY	GG25 CAST IRON
2	SCREW	8.8 CARBON STEEL
3	HINGE	GG25 CAST IRON
4	SWING	GG25 CAST IRON
5	GASKET	NBR REINFORCED
6	WASHER	CARBON STEEL DN40-DN150
6	WASHER	GG25 CAST IRON DN200-DN300
7	NUT	CARBON STEEL
8	SEAT	CAST BRASS
9	PIN	DRAWN BRASS
10	GASKET	SBR RUBBER
11	BONNET	GG25 CAST IRON

Max temperature +80°C

DN	40	50	65	80	100	125	150	200	250	300
F	150	165	185	200	220	250	285	340	405	460
L	180	200	240	260	300	350	400	500	600	700
H	115	125	130	140	160	180	200	220	290	330
A	193	193	218	243	278	306	356	406	575	575
Kg	9	10	15	20	26	36	50	73	134	199

F = ISO 7005-2 PN16

L = EN 558-1 BASIC SERIES 48

Hydraulic test ISO 5208 RATE A

Maximum rated pressure in
relation to temperature
and material

Pressure	Temperature
16 bar	-10°C/+80°C