

# J0421

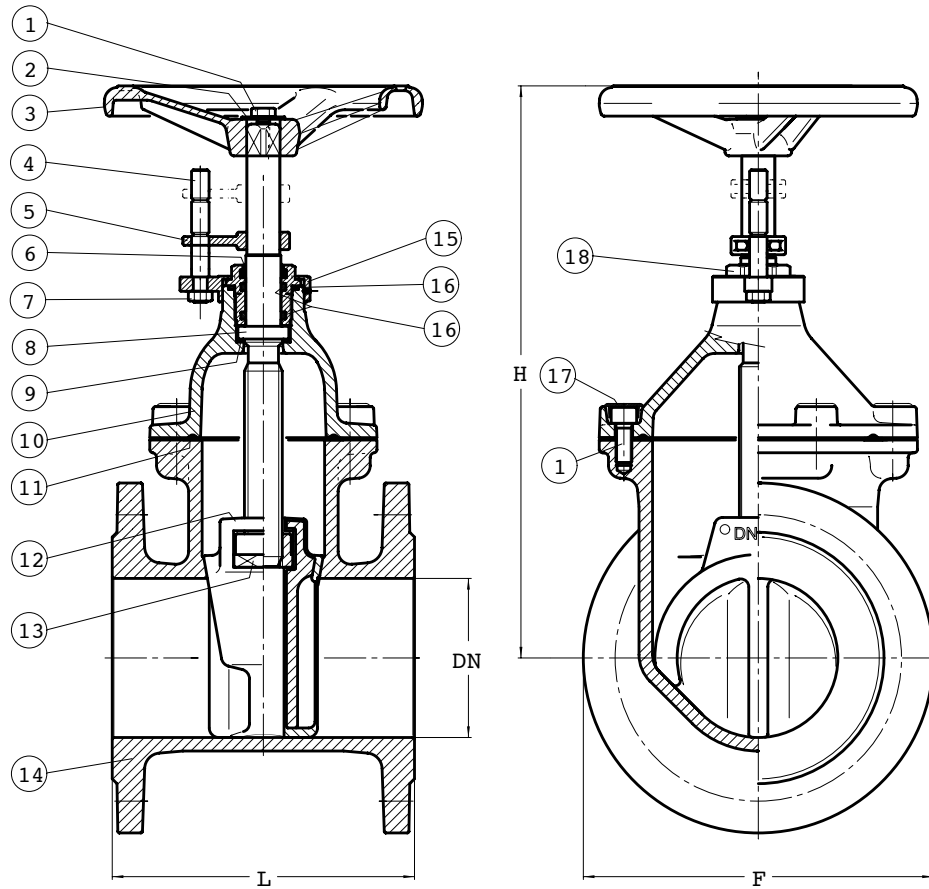

POS.	PARTS	MATERIALS
1	SCREW	ZINC-PLATED 8.8 CARBON STEEL
2	WASHER	ZINC-PLATED CARBON STEEL
3	HANDWHEEL	GG25 CAST IRON
4	INDICATOR	DRAWN BRASS
5	FORK	CAST BRASS
6	DUST PROOF PACKING	PVC
7	NUT	ZINC-PLATED CARBON STEEL
8	STEM	X10Cr13
9	BACK SEAT	PTFE
10	BONNET	GGG40 DUCTILE CAST IRON
11	GASKET	EPDM RUBBER
12	WEDGE	GGG40 DUCTILE CAST IRON VULCANIZED EPDM
13	MOTHERSCREW	CAST BRASS
14	BODY	GGG40 DUCTILE CAST IRON
15	INDICATOR SUPPORT	CAST BRASS
16	O-RING	EPDM RUBBER
17	SCREW TAP	HOT GLUE
18	BUSH	DRAWN BRASS

Max temperature +70°C

DN	40	50	65	80	100	125	150	200	250	300
F	150	165	185	200	220	250	285	340	405	460
L	140	150	170	180	190	200	210	230	250	270
H	245	255	290	320	360	425	470	565	670	765
Kg	9	10	13	16	21	27	34	54	84	110

Hydraulic Test ISO 5208 RATE A	
Maximum rated pressure	
Pressure	Temperature
16 bar	-10°C/+70°C

F = ISO 7005-2 PN16 L = ISO 5752 BASIC SERIES 14

Reimer Armaturen GmbH - Tel.: +49 421 2010150 - Fax.: 49 421 2010151 - Mail: ra@r-a.de - www.armaturenshop.de